

Dimensions

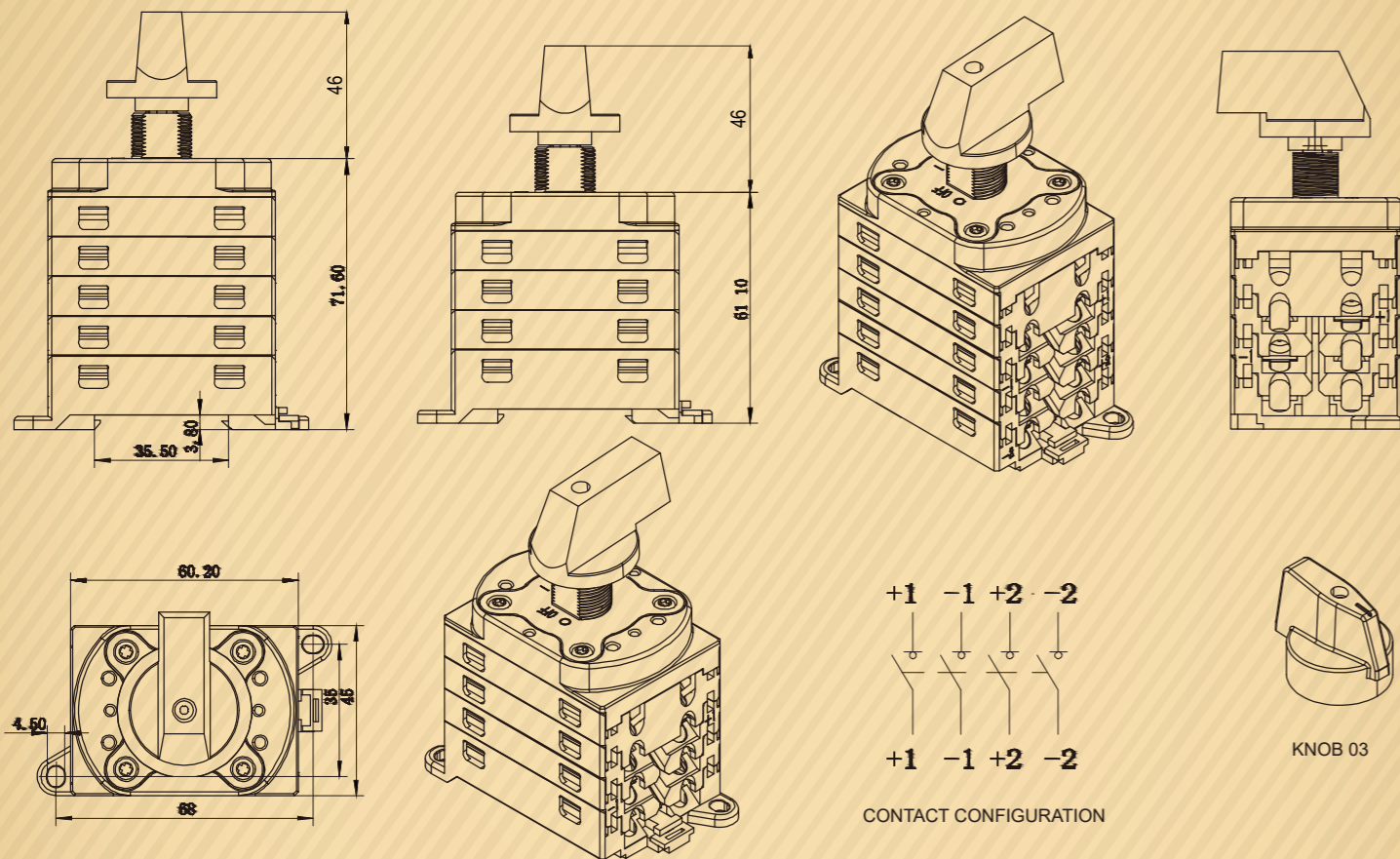

DISTRIBUTION BOARD
DC ISOLATOR

PEDS150-DB-X

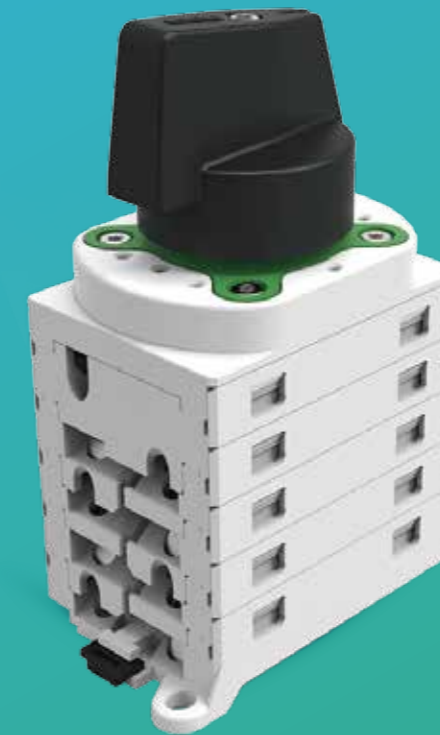



Product Features













1. Compact structure, modular design, level 2-8 with different versions are dispensable, satisfied to the need of different situations.
2. Ding rail and base type isolator are applicable to control box, distribution box and combiner box, and achieve IP20 using imported seal parts.
3. Incorporating a user independent switching action, spring mechanism, to ensure a very fast break/make action which means the disconnection of the load circuits and suppression of the arc is normally extinguished in a maximum of 5ms.
4. Improving design of the contact touch, increasing the interface of contact, stamina, improving the roughness of the surface, making sure contacts has high touch function when contacts are from separate to together or from together to separate.
5. The torque of isolator is 1nm, and the cable terminals match 4mm²~16mm² cable terminals.
6. SAFE-LOCK with three rotational positions reducing the risks of tampering.
7. Rated DC voltage is 1500V, with international certifications like IEC60947-3, UL508i, GB14048.3 etc.

Technical data

Data according to IEC60947-3(ed.3.2):2015,UL508i,GB14048.3. Utilization category DC-PV0 / DC-PV1.

Main Parameters		Type	DB16	DB25	DB32
Rated insulation voltage	U_i	V	1500	1500	1500
Rated thermal current	I_{the}	A	16	25	32
rated impulse withstand voltage	U_{imp}	V	8000	8000	8000
rated short-time withstand current (1s)	I_{cw}	2, 4, 6, 8	800	900	1000
		2H, 3H, 4H	1300	1500	1700
rated short-circuit making capacity	I_{cm}	2, 4, 6, 8	800	900	1000
		2H, 3H, 4H	1300	1500	1700
rated conditional short-circuit current	I_{cc}	A	5000	5000	5000
Max. fuse size	g_t (gG)	A	40	63	80
Maximum cable cross sections (incl. jumper)					
solid or standard		mm ²	4-16	4-16	4-16
flexible		mm ²	4-10	4-10	4-10
flexible (+ multicore cable end)		mm ²	4-10	4-10	4-10
Torque					
Tightening torque terminal screws M4.		Nm	1.2-1.3		
Tightening torque panel mounting screws ST4.2(304 stainless steel)		Nm	NA		
Tightening torque single hole mounting nut M16		Nm	NA		
Tightening torque knob screws M3		Nm	0.5-0.7		
Switching on or off torque		Nm	0.9-1.9		
Power loss per switch Max.					
2	W		0.8	2	3
4	W		1.6	4	6
6	W		2.4	6	9
8	W		3.2	8	12
2H	W		0.4	1	1.5
3H	W		0.6	1.5	2.25
4H	W		0.8	2	3
General parameters					
method of mounting	Ding rail mounting and base mounting				
type of knob	A		B		
					
knob positions	OFF at 12 hr, ON at 3 hr; (OFF at 9 hr, ON at 12 hr optional)				
Mechanical life	10,000				
number of DC poles	2 or 4 (6/8 pole optional)				
Distance of contacts (per pole)	mm	80			
Operation temperature	°C	-40 to +70			
Storage temperature	°C	-40 to +85			
Pollution degree	2				
Overvoltage category	III				
IP rating	IP20				

Technical data

Data according to IEC60947-3(ed.3.2):2015,UL508i,GB14048.3. Utilization category DC-PV0/DC-PV1.								Poles in series	No. of Strings	Part Number	Contact Configuration
500V	600V	700V	800V	900V	1000V	1200V	1500V				
9	6	4.5	3	2.5	1.5	/	/	1	1	PEDS150-DB16-1	
11	8	6	4	3	2	/	/	1	1	PEDS150-DB25-1	
13	10	7.5	5	4	2.5	/	/	1	1	PEDS150-DB32-1	
16	16	16	16	13	9	6	3	2	1	PEDS150-DB16-2	
25	25	23	20	16	11	8	4	2	1	PEDS150-DB25-2	
32	32	27	23	20	13	10	5	2	1	PEDS150-DB32-2	
16	16	16	16	13	9	6	3	2	2	PEDS150-DB16-3	
25	25	23	20	16	11	8	4	2	2	PEDS150-DB25-3	
32	32	27	23	20	13	10	5	2	2	PEDS150-DB32-3	
29	29	16	16	13	9	6	3	2	1	PEDS150-DB16-2H	
45	45	23	20	16	11	8	4	2	1	PEDS150-DB25-2H	
58	50	27	23	20	13	10	5	2	1	PEDS150-DB32-2H	
16	16	16	16	13	9	6	3	2	2	PEDS150-DB16-4	
25	25	23	20	16	11	8	4	2	2	PEDS150-DB25-4	
32	32	27	23	20	13	10	5	2	2	PEDS150-DB32-4	
16	16	16	16	16	16	16	16	4	1	PEDS150-DB16-4S	
25	25	25	25	25	25	25	20	4	1	PEDS150-DB25-4S	
32	32	32	32	32	32	32	23	4	1	PEDS150-DB32-4S	
16	16	16	16	16	16	16	16	4	1	PEDS150-DB16-4T	
25	25	25	25	25	25	25	20	4	1	PEDS150-DB25-4T	
32	32	32	32	32	32	32	23	4	1	PEDS150-DB32-4T	
16	16	16	16	16	16	16	16	4	1	PEDS150-DB16-4B	
25	25	25	25	25	25	25	20	4	1	PEDS150-DB25-4B	
32	32	32	32	32	32	32	23	4	1	PEDS150-DB32-4B	
16	16	16	16	13	9	6	3	2	3	PEDS150-DB16-6	
25	25	23	20	16	11	8	4	2	3	PEDS150-DB25-6	
32	32	27	23	20	13	10	5	2	3	PEDS150-DB32-6	
29	29	29	29	29	29	12	9	3	1	PEDS150-DB16-3H	
45	45	38	38	38	38	14	11	3	1	PEDS150-DB25-3H	
58	50	45	45	45	45	16	13	3	1	PEDS150-DB32-3H	
16	16	16	16	13	9	6	3	2	4	PEDS150-DB16-8	
25	25	23	20	16	11	8	4	2	4	PEDS150-DB25-8	
32	32	27	23	20	13	10	5	2	4	PEDS150-DB32-8	
29	29	29	29	29	29	29	16	4	1	PEDS150-DB16-4H	
45	45	45	45	45	45	45	20	4	1	PEDS150-DB25-4H	
58	58	58	58	58	58	50	23	4	1	PEDS150-DB32-4H	
16	16	16	16	16	16	16	16	4	2	PEDS150-DB16-8(4S*2)	
25	25	25	25	25	25	25	20	4	2	PEDS150-DB25-8(4S*2)	
32	32	32	32	32	32	32	23	4	2	PEDS150-DB32-8(4S*2)	